

FKS F3 Phy S3 Final (2024-2025)

Physics
(1 hour)

Date: 3rd June 2025

Time: 10:15 a.m. – 11:15 a.m.

Name: _____

Class: _____ No.: _____

Instructions to students:

1. Write your name, class and class number on both the question paper and the answer sheets.
2. Answer ALL questions.
3. Write down all the answers on the answer sheets.
4. Hand in the question paper and the answer sheets at the end of the examination.
5. The total mark of the paper is 60.
6. The paper consists of two sections: Section A Multiple Choice Questions (20 marks) and Section B Structured Questions (40 marks).
7. The numerical answers should be either exact or correct to 3 significant figures.

Section A: Multiple Choice Questions (20 marks)

1. Which of the following statements about the reflection of light is/are correct?
 - (1) It only occurs on smooth surfaces.
 - (2) It always follows the laws of reflection.
 - (3) When incident rays are parallel, clear images will be formed.

A. (1) only
B. (2) only
C. (2) and (3) only
D. (1), (2) and (3)

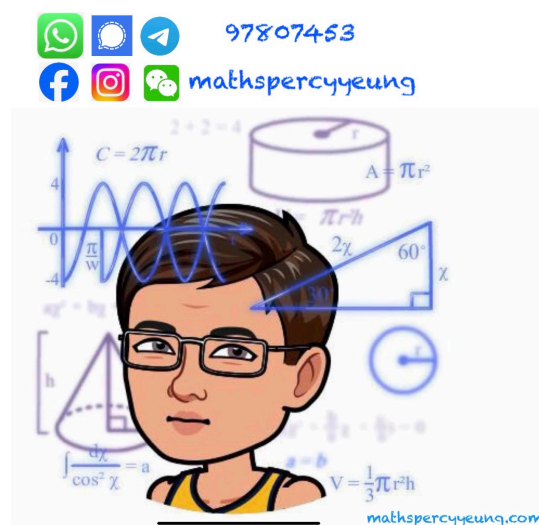

2. Which of the following diagrams shows the correct position of image I of object O formed by the plane mirror?

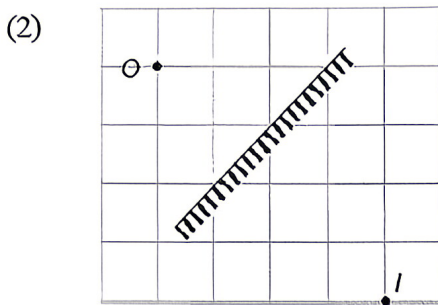
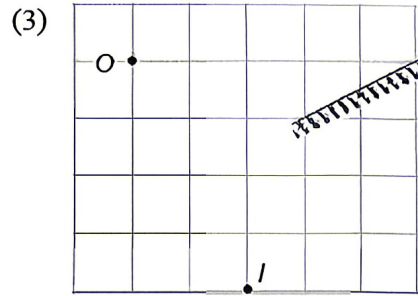
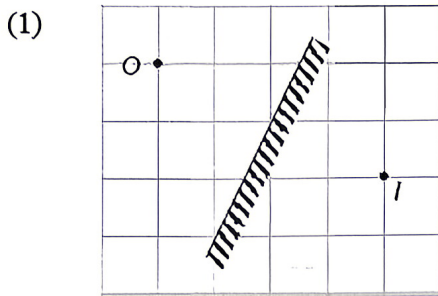

- A. (1) only
- B. (2) only
- C. (1) and (3) only
- D. (1), (2) and (3)

3. A 158 cm tall girl stands 1.5 m from a wall mirror as shown below. Her eyes are 148 cm above the floor. The girl can just see the bottom of her skirt, which is 40 cm above the floor, in the mirror. What is the height of the bottom edge of the mirror above the floor?

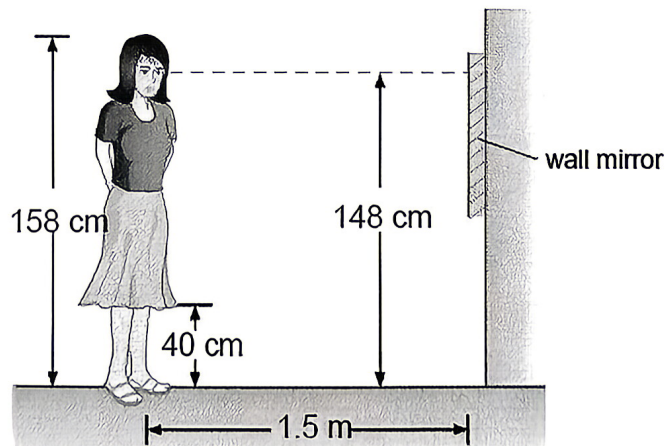

- A. 40 cm
- B. 54 cm
- C. 80 cm
- D. 94 cm

4. A light ray bends towards the normal when it travels from medium P to medium Q . Which of the following statements is incorrect?
- A. The light speed in medium P is higher than that in medium Q .
 - B. The refractive index of medium P is greater than that of medium Q .
 - C. With respect to vacuum, the critical angle of medium P is larger than that of medium Q .
 - D. Total internal reflection will not occur no matter how large the angle of incidence in medium P is.

5. A ray of light travels from medium X to medium Y as shown below. Which of the following gives the ratio of the speed of light in X to that in Y ?

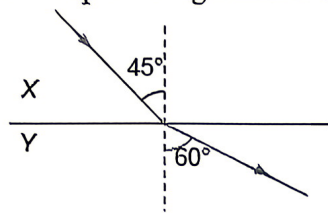

- A. 3 : 4
 - B. $\sqrt{3} : \sqrt{2}$
 - C. 4 : 3
 - D. $\sqrt{2} : \sqrt{3}$
6. P is an emergent ray from a lens as shown below. F and F' are the principal foci of the lens. Which of the following rays is a possible incident ray?

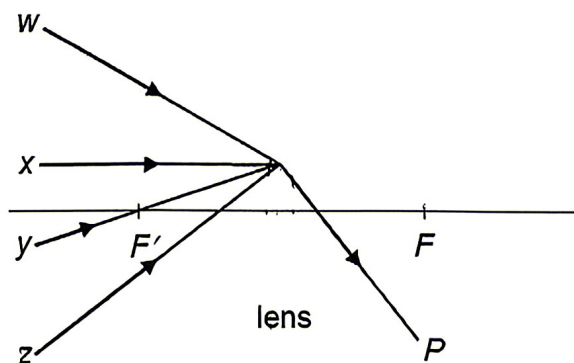

- A. Ray w
- B. Ray x
- C. Ray y
- D. Ray z

7. An object is put in front of a lens and a virtual image is formed. The figure below shows the positions of the object and the image. What is the focal length of the lens?

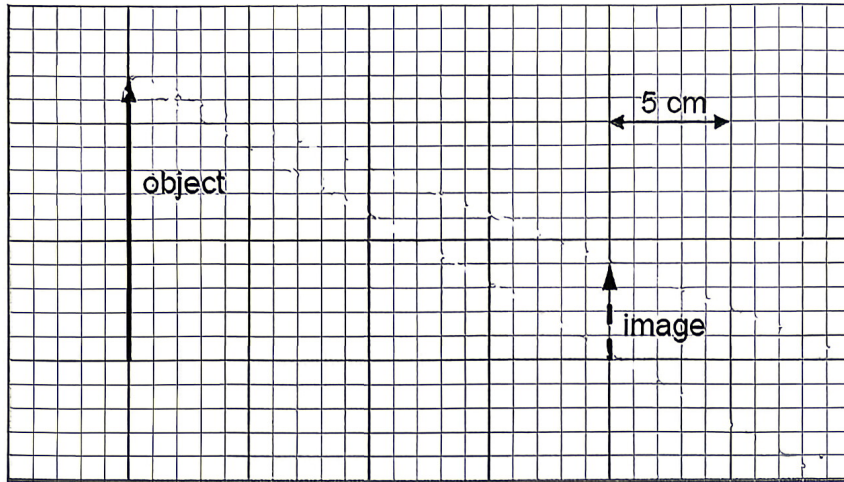

- A. 5 cm
 B. 10 cm
 C. 15 cm
 D. 20 cm
8. In the diagram below, intervals AB , BC , CD , DE and EF are of equal length. An object is placed at O . When a lens is put in front of the object, an image of the object is formed at I .

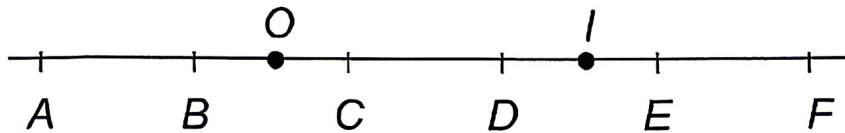

Which of the following show(s) the possible position(s), type(s) and focal length(s) of the lens?

	Position	Type	Focal length
(1)	F	concave lens	about 2 intervals
(2)	C	convex lens	about 1 interval
(3)	D	convex lens	about 1 interval

- A. (1) only
 B. (2) only
 C. (1) and (3) only
 D. (2) and (3) only

9. A cork floating on the water surface vibrates up and down 12 times in 4 s when a wave passes through it. The distance between two successive troughs of the wave is 12 cm. What is the speed of the wave?
- A. 0.04 m s^{-1}
B. 0.36 m s^{-1}
C. 0.48 m s^{-1}
D. 1.44 m s^{-1}
10. A transverse wave is travelling from left to right in a medium. The frequency of the wave is 0.2 Hz. The figure below shows the waveform at time $t = 0$.

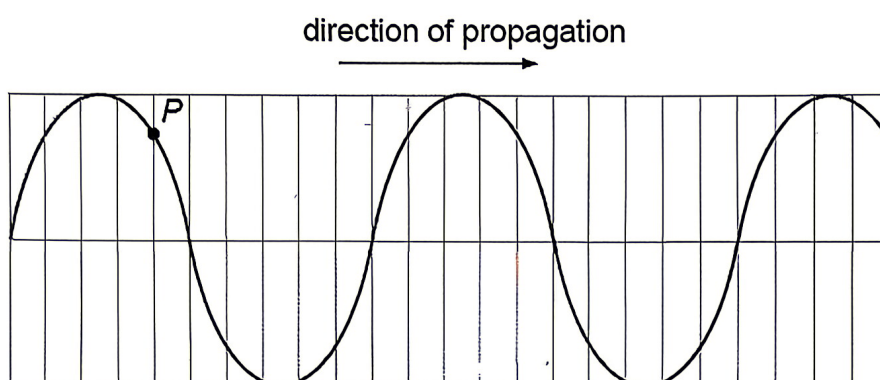

When will particle P return to its position as shown above for the first time.

- A. $t = 1.5 \text{ s}$
B. $t = 2.5 \text{ s}$
C. $t = 3.5 \text{ s}$
D. $t = 5 \text{ s}$

End of Section A

Section B: Structured Questions (40 marks)

- A small point object O is in front of a plane mirror. Figure 1 on the answer sheet shows the reflected rays of two light rays travelling from O to the mirror.

 - Locate the image of O in Figure 1. (2 marks)
 - Shade the largest region in which an observer can see the image of O in Figure 1. (2 marks)

- Figure 2.1 shows a well illuminated dining room. There is a clock hanging on the wall at C . Samson stands at point S and faces the window which is fitted with a clear glass pane from the ceiling to the floor. It is dark outside. Samson can see the clock's image in the window.

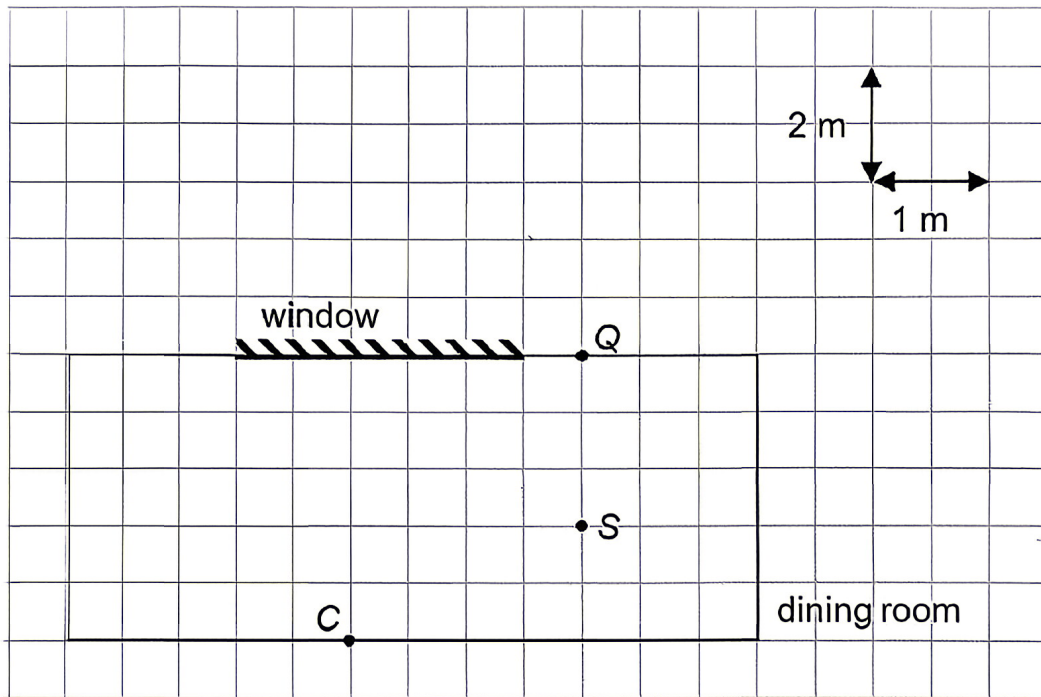

Figure 2.1

- Figure 2.2 shows the image of the clock. What is the true time shown by the digital clock? (1 mark)

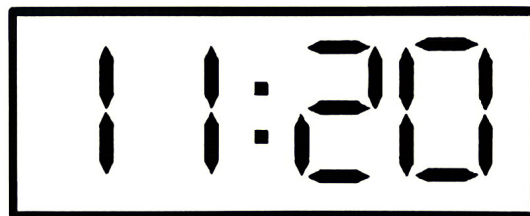

Figure 2.2

- Is the image of the clock real or virtual? (1 mark)
- Then Samson walks from S towards Q along a straight line. What is the minimum distance of Samson from Q such that he can still see the clock's image in the window? (3 marks)

3. An object O is put in medium X . Figure 3 on the answer sheet shows one light ray from O travelling towards medium Y . The refractive index of medium Y is 1.2.
- (a) Find the refractive index of medium X . (2 marks)
- (b) Sketch a light ray in Figure 3 to show how an observer at P can see object O . (1 mark)
4. As shown in Figure 4 on the answer sheet, a monochromatic light beam is directed from air to a glass prism. It makes an angle of 67° to side AB of the prism.
- (a) Find the refractive index of the prism. (2 marks)
- (b) Find the angle of incidence when the light beam hits side AC . (2 marks)
- (c) Determine whether some of the light escapes side AC . (2 marks)
- (d) In Figure 4, draw all the possible path(s) of the light beam just after it hits side AC . (1 mark)
5. As shown in Figure 5 on the answer sheet, an object is placed in front of lens L and light ray from the object is refracted by L .
- (a) What type of lens is L ? (1 mark)
- (b) By adding one suitable light ray to Figure 5, find and label the image formed. (2 marks)

6.

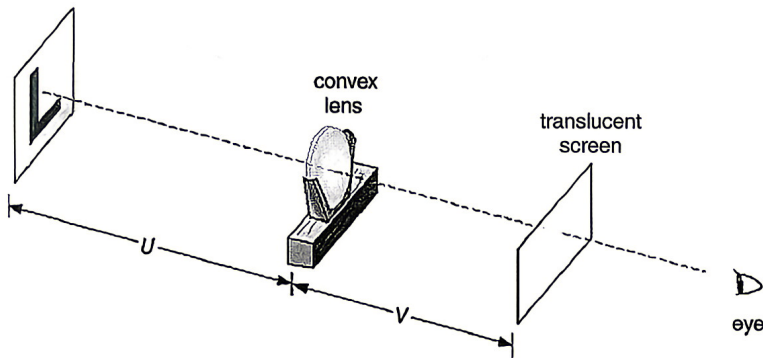

Figure 6.1

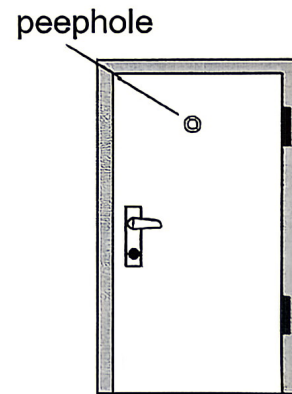

Figure 6.2

- (a) In Figure 6.1, an illuminated letter 'L' is placed 30 cm in front of a convex lens and its image formed by the lens is caught by a translucent screen. The image is half as large as the object.
- (i) Sketch the shape of the image seen by the observer. (1 mark)
- (ii) Find the image distance and the focal length of the lens. (3 marks)
- (b) Figure 6.2 shows a peephole that is usually installed on the main door of a house.
- (i) Which kind of lens is used in a peephole? (1 mark)
- (ii) By considering the image nature, give two advantages of using this kind of lens in a peephole. (2 marks)

7. Radio waves and X-rays belong to a family of waves that can travel at the speed of light in vacuum.

- (a) State the full name of this family of waves. (1 mark)
- (b) Which wave in this family is used in the following cases? (2 marks)
- (i) Radiotherapy for killing cancer cells



Figure 7.1

- (ii) Examining the duodenum (十二指腸) with an endoscope (內窺鏡)

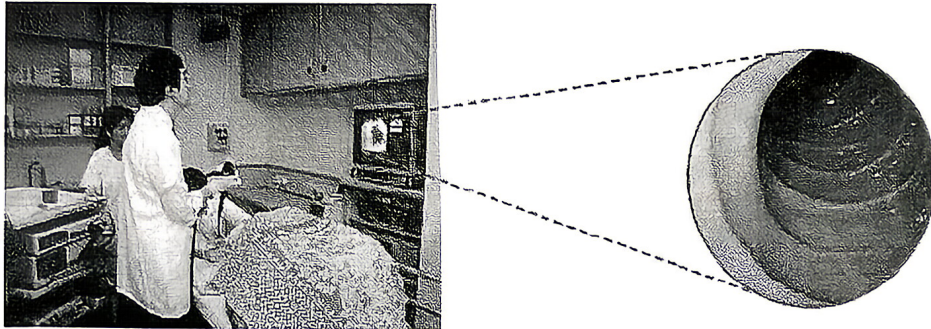

Figure 7.2

- (c) State and explain the observed colour of a blue object under red light. (2 marks)

8. A transverse wave is travelling to the left along a string. Figure 8 on the answer sheet shows the snapshot of a section of the wave at time $t = 0$. P and Q are two particles on the string. The period and wavelength of the wave are 2 s and 2.5 cm respectively.

- (a) State the motion of particles P and Q at time $t = 0$. (2 marks)
- (b) Draw the waveform at $t = 1$ s. Mark the positions of P and Q at $t = 1$ s. (2 marks)
- (c) If the period of the string wave is shortened, how does the wave speed and wavelength change? (2 marks)

End of Section B
END OF PAPER

S3 Final Examination (2024–2025)

Physics
Answer Sheet
(1 hour)

Date: 3rd June 2025

Time: 10:15 a.m. – 11:15 a.m.

Name: _____

Class: _____ No.: _____

Section A: Multiple Choice Questions (20 marks)

1.	2.	3.	4.	5.	6.	7.	8.	9.	10.

Section B: Structured Questions (40 marks)

1. (a), (b)

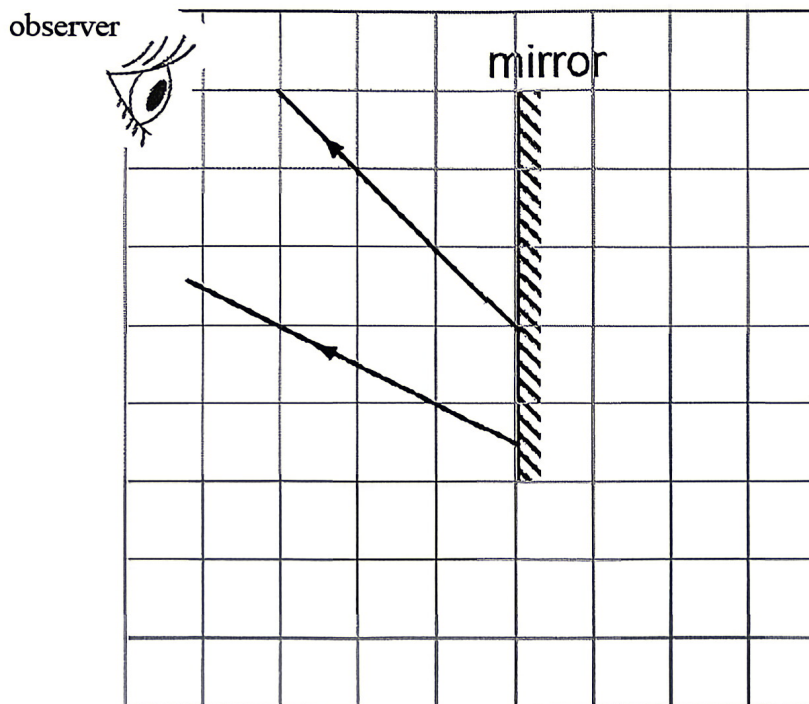

Figure 1

2. (a) _____
 (b) _____
 (c) _____

3. (b)

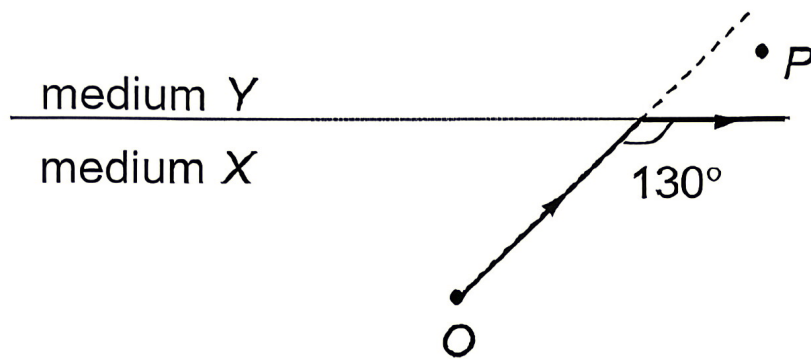

Figure 3

- (a) _____

4. (d)

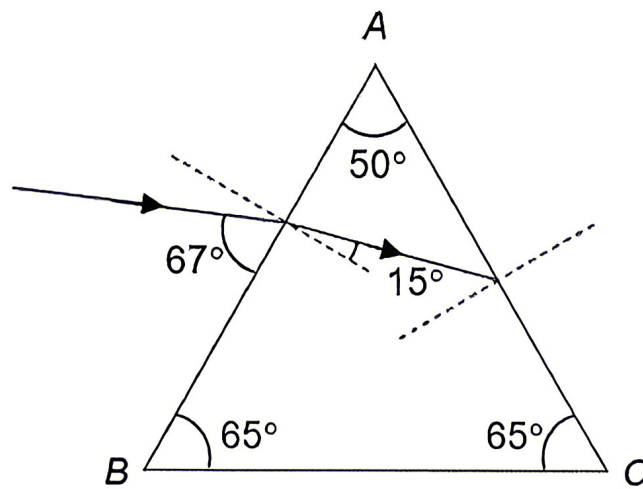

Figure 4

(a) _____

(b) _____

(c) _____

5. (b)

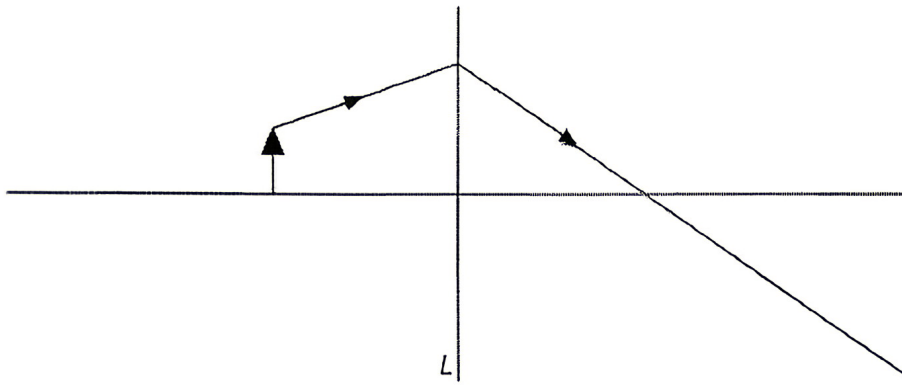
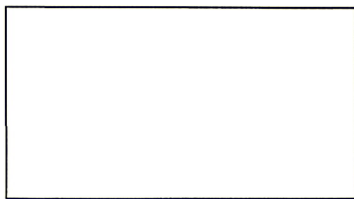

Figure 5

(a) _____

6. (a) (i)



(ii) _____

(b) (i) _____

(ii) _____

7. (a) _____

(b) (i) _____

(ii) _____

(c) _____

8. (b)

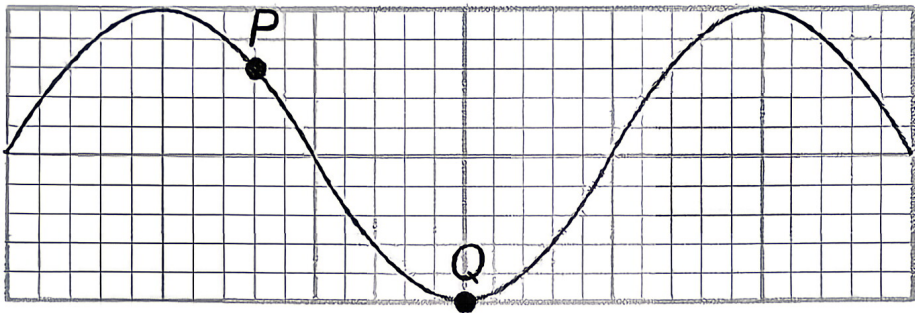

Figure 8

(a) _____

(c) _____

END OF ANSWER SHEET