

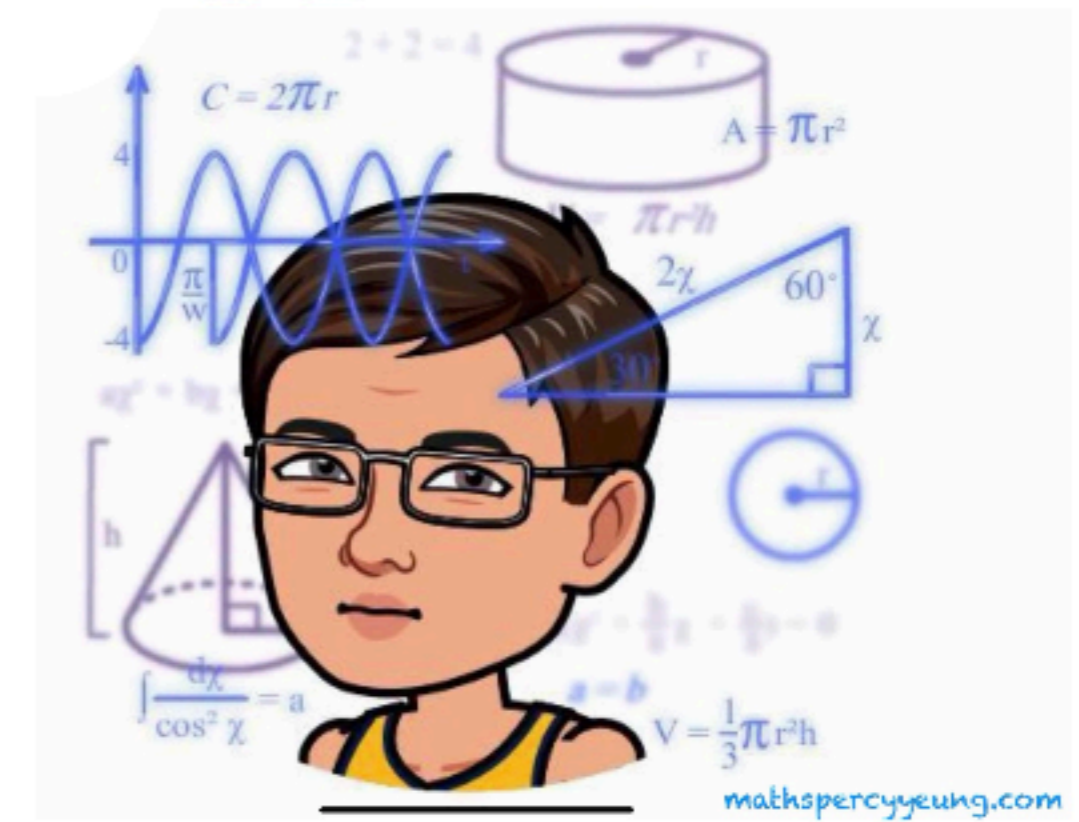

Mathematics  
(2 hours)

Date: 3<sup>rd</sup> June, 2024

Time: 8:30 a.m. - 10:30 a.m.



**Instructions to students:**

1. This paper consists of THREE parts, Conventional Questions, Multiple-choice Questions and Bonus Question. There are Section A and Section B in Conventional Questions. Section A carries 48 marks, Section B carries 32 marks, Multiple-choice Questions carry 20 marks and Bonus Question carries 3 marks.
2. The maximum score of this paper is 100.
3. Attempt **ALL** questions in Conventional Questions and Multiple-choice Questions. Write your answers in the spaces provided in this Question / Answer Book.
4. Unless otherwise specified, show your workings clearly.
5. Unless otherwise specified, numerical answers should either be exact or correct to 3 significant figures.
6. The diagrams in this paper are not necessarily drawn to scale.

**Conventional Questions****Section A1 (48 marks)**

1. Make  $a$  the subject of the formula  $\frac{2}{a+b} = \frac{b}{a-7}$ .

(3 marks)

2. Simplify  $\frac{x^{-6}y}{(x^5y^{-7})^{-8}}$  and express your answer with positive indices.

(3 marks)

3. Factorize

(a)  $m^2 - mn - 2n^2$ ,

(b)  $m^2 - mn - 2n^2 - 3m + 6n$ .

(3 marks)

4. (a) Solve the inequality  $5x + 3 \geq \frac{13x - 9}{2}$ .
- (b) How many positive integers satisfy the inequality in (a)?

(3 marks)

5. In Figure 1,  $L_1$  passes through  $A(2, -4)$  and  $B(-3, 1)$  while  $L_2$  passes through  $C(6, 2)$ . It is given that  $L_1 \parallel L_2$ .

- (a) Find the slope of  $L_1$ .
- (b) Find the  $x$ -intercept of  $L_2$ .

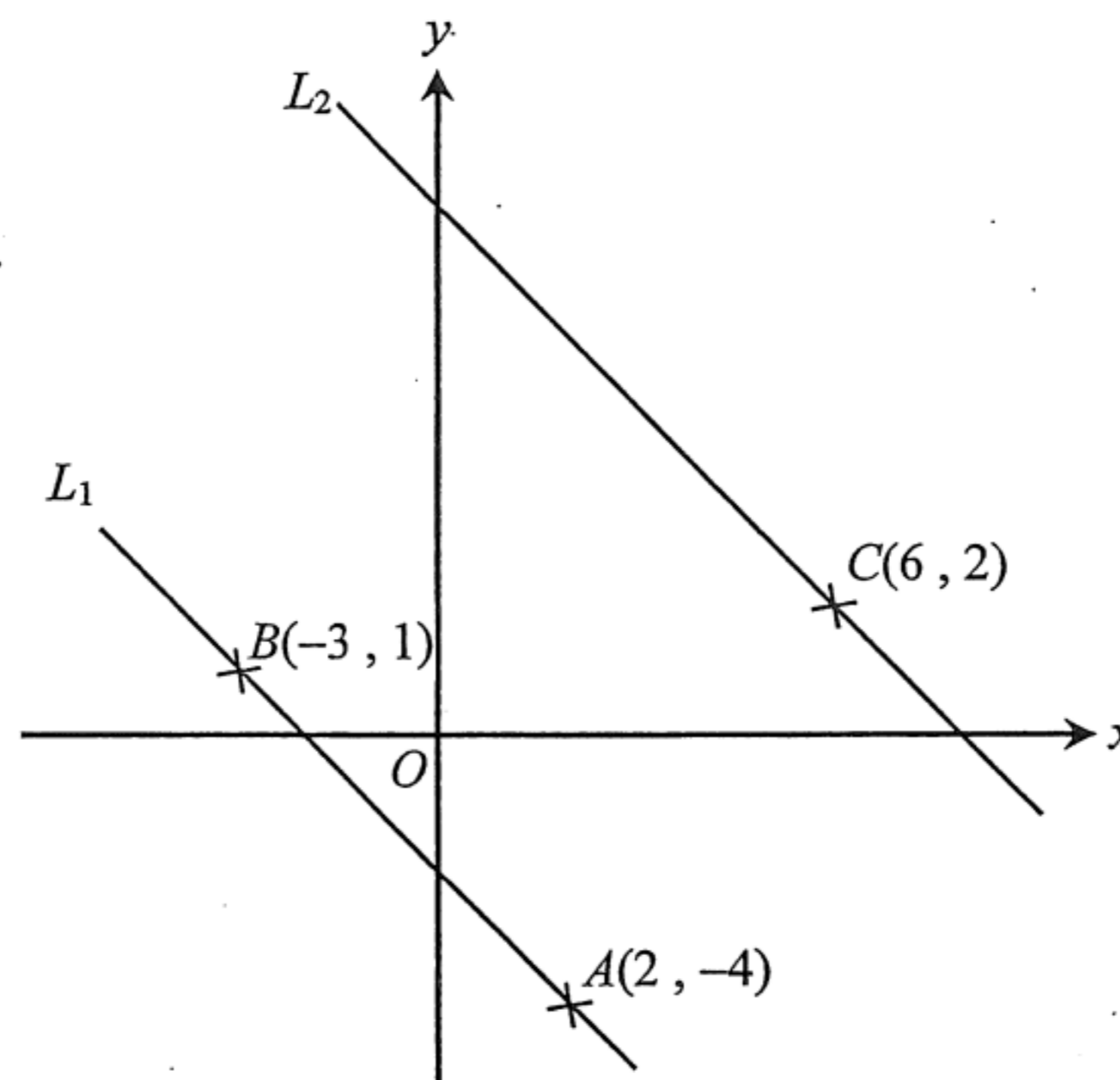

Figure 1

(3 marks)

6. The table below shows the distribution of the ages of 50 members in a club.

Age less than	Cumulative frequency
60	50
50	38
40	$x$
30	$\frac{x}{2}$

It is given that the ratio of the number of the members aged from 50 to 59 and that of the members aged from 30 to 39 is 6:5.

- (a) Find  $x$ .
- (b) A member in the club is chosen at random. Find the probability that the age of the chosen member is between 40 and 49.

(4 marks)

7. The actual area of the bedroom of a flat is  $8 \text{ m}^2$  and its area on a plan is  $32 \text{ cm}^2$ .

- (a) If the scale of the plan is  $1 : k$ , find the value of  $k$ .
- (b) The actual area of the flat is  $40 \text{ m}^2$ . Find the area of its plan.

(4 marks)

8. Ken bought a computer 2 years ago. The depreciation rate is 20% every 6 months. Its depreciation is \$7 380 now.
- (a) Find the original price of the computer.
- (b) When the present value of the computer is less than \$5 000, Ken will buy a new computer. Will he buy a new computer now? Explain your answer. (4 marks)

9. Figure 2 shows the vertical cross section of a rectangular box  $ABCD$  that leans against a vertical wall. The length and the height of the box are 2.2 m and 0.9 m respectively. The side  $BC$  makes an angle of  $34^\circ$  with the horizontal ground. Angus claims that the vertical height of  $A$  above the ground is over 2 m. Do you agree? Explain your answer. (4 marks)

Join  $AC$  and draw  $AE$  such that  $AE \perp CE$ .

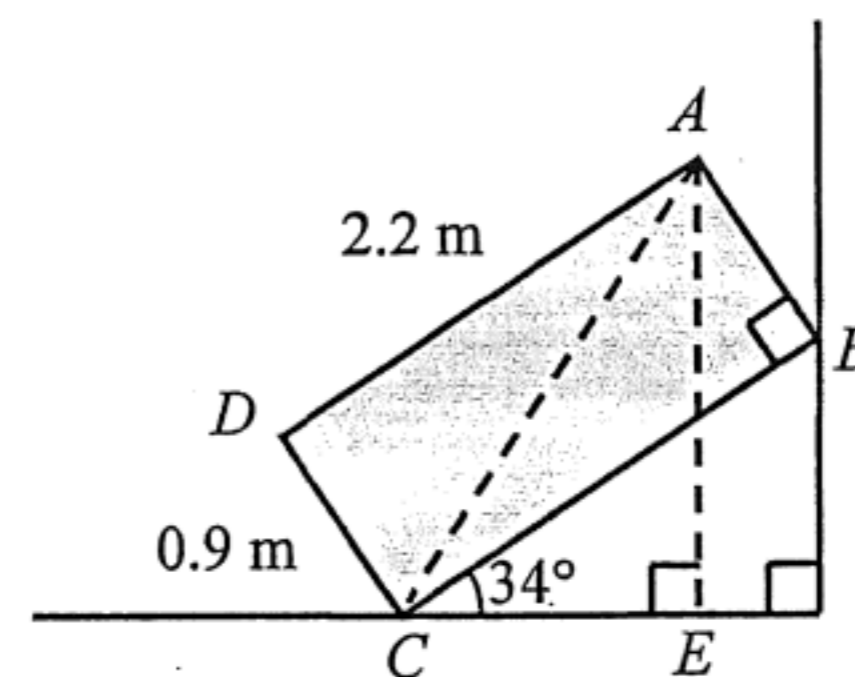

10. Two fair dice are thrown at the same time.

- (a) Use a table to list all the possible outcomes and write down the total number of possible outcomes.
- (b) Find the probability of each of the following events.
  - (i) The two numbers obtained are both even numbers.
  - (ii) The sum of the two numbers obtained is not less than 10.
- (c) The two fair dice are thrown at the same time for 600 times. What is the expected number of times of getting only one '6'?

(5 marks)

11. The stem-and-leaf diagram below shows the distribution of the ages of the employees in a company.

<u>Stem (tens)</u>	<u>Leaf (units)</u>				
2	$a$	3	6	7	
3	0	1	2	5	7 7
4	4	4	5	6	9
5	0	0	$b$		

It is given that the difference between the greatest and the smallest values of the distribution is 36 and the mean of the distribution exceeds 38.

- (a) Find  $a$  and  $b$ .
- (b) A new employee now joins the company.
- (i) Is there any change in the median of the distribution due to the additional employee? Explain your answer.
- (ii) If the mode of the distribution becomes 23, find the lower quartile of the distribution.

(6 marks)

12. The slant height and the curved surface area of a solid metal right circular cone are 29 cm and  $580\pi$  cm<sup>2</sup> respectively.
- (a) Find the height of the circular cone.
  - (b) The circular cone is divided into three parts by two planes which are parallel to its base. The top part is a right circular cone  $A$ , the middle part is a frustum  $B$  and the bottom part is a frustum  $C$ . The curved surface areas of  $A$  and  $B$  are equal. The curved surface area of  $C$  is 6 times the curved surface area of  $A$ . Express the volume of  $C$  in terms of  $\pi$ .

(6 marks)

## Section B (32 marks)

13. In Figure 3,  $ABCD$  is a trapezium with  $AD \parallel BC$ .  $AC$  and  $BD$  intersect at  $E$ . It is given that  $\angle ABD = \angle DAE$  and  $\angle BAD = 90^\circ$ .

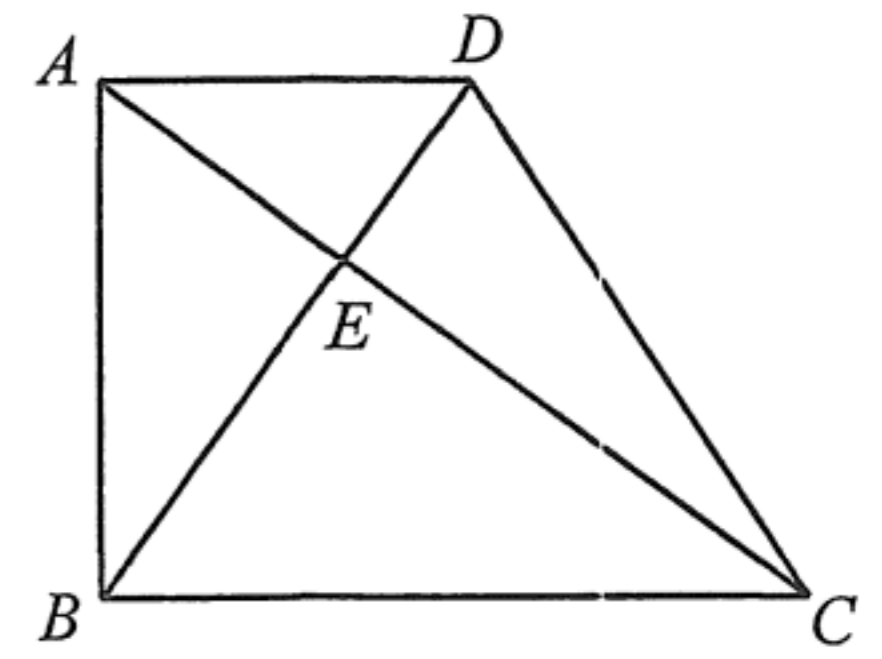

(a) Prove that

(i)  $\triangle ADE \sim \triangle CBE$ ,

(ii)  $\triangle ABD \sim \triangle EAD$ .

(b) It is given that  $AE = 72$  cm and  $DE = 54$  cm.

(i) Find  $BE$ .

(ii) Is there a point  $F$  lying on  $BD$  such that the distance between  $C$  and  $F$  is less than 125 cm?

Explain your answer.

(8 marks)

14. Figure 4(a) shows a solid metal right cylinder of base radius 36 cm and height 108 cm.

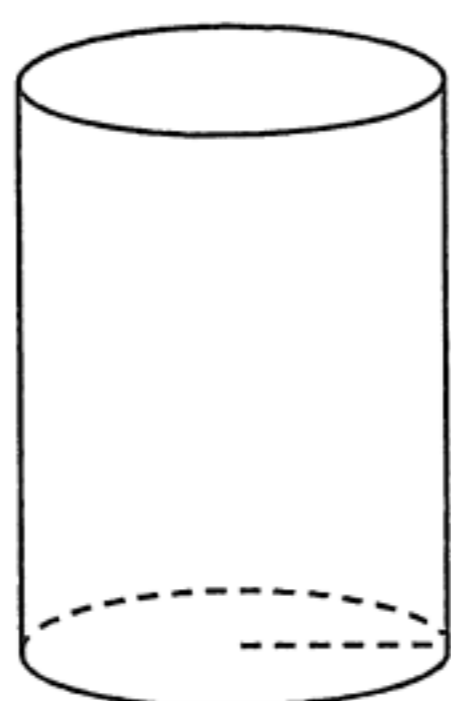

Figure 4(a)

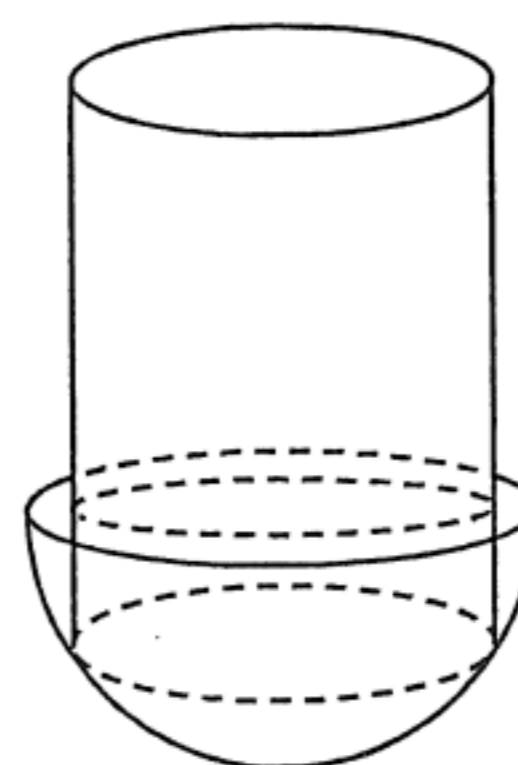

Figure 4(b)

- (a) A hemispherical vessel of radius 45 cm is held vertically on a horizontal surface. The vessel is fully filled with water. Find the volume of the water in terms of  $\pi$ .
- (b) The cylinder is now held vertically in the vessel as shown in Figure 4(b).
- (i) Someone claims that the volume of the water remaining in the vessel is more than  $0.08 \text{ m}^3$ . Do you agree? Explain your answer.
- (ii) Find the total area of all the wet surfaces in terms of  $\pi$ .

(8 marks)

15.  $A$ ,  $B$  and  $C$  are three cities lying on the same horizontal plane.  $A$  is in the direction of  $N22^\circ E$  from  $B$ ,  $B$  and  $C$  are 15 km apart and  $C$  is due east of  $B$ , and  $A$  is in the direction  $N56^\circ W$  from  $C$ . It is given that a power station is built at a position  $P$  such that  $P$  is the incentre of  $\triangle ABC$ . Find

- (a) Draw a figure showing the locations of  $A$ ,  $B$ ,  $C$  and  $P$ .
- (b) Find the true bearing of the power station from city  $C$ ,
- (c) Find the distance between the power station and city  $C$ , correct to 3 significant figures.

(8 marks)

16.  $PQRS$  is a rhombus on the rectangular coordinate plane. The coordinates of points  $P$  and  $R$  are  $(2, 2)$  and  $(6, 4)$  respectively. The diagonals  $PR$  and  $QS$  intersect at point  $M$ . It is given that point  $Q$  lies on the  $x$ -axis.
- Find the coordinates of  $M$ .
  - Find the coordinates of  $Q$  and  $S$ .
  - If  $N$  is a point lying on  $QS$  produced such that  $QM : MN = 3 : 5$ , find
    - the coordinates of  $N$ ,
    - the area of quadrilateral  $PSRN$ .

(8 marks)

Refer to the figure

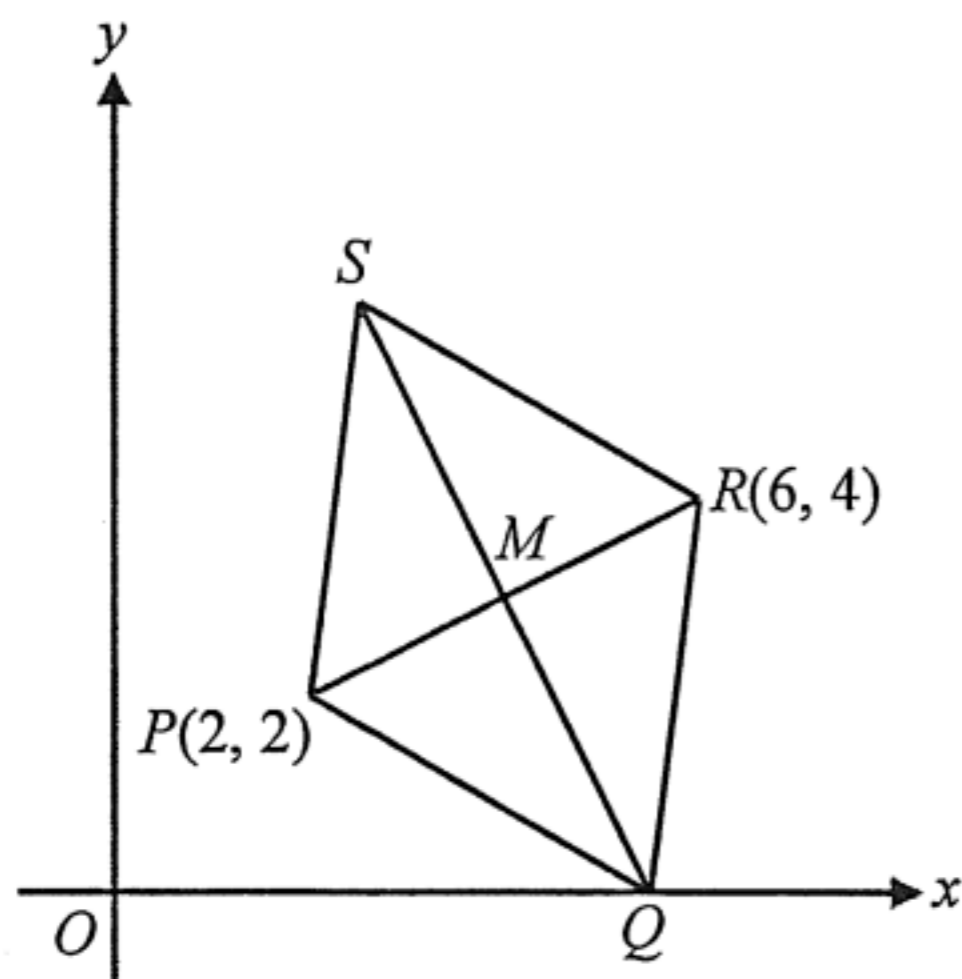



**Multiple-choice Questions (20 marks)**

Each question carries 2 marks. Put  $\checkmark$  in the correct boxes.

	17	18	19	20	21	22	23	24	25	26
A										
B										
C										
D										

17. If  $a > b$ , which of the following must be true?

- I.  $a^2 > b^2$
  - II.  $a - k > b - k$ , where  $k$  is a negative number
  - III.  $-a < -b$
- A. I only
  - B. II only
  - C. I and III only
  - D. II and III only

18. In Figure 5, a metal ball is dropped into a set tubes arranged in 3 levels. Assume that the chances of the ball moving left or right at each level are the same. Find the probability that the ball reaches B or C.

- A.  $\frac{1}{4}$
- B.  $\frac{3}{8}$
- C.  $\frac{5}{8}$
- D.  $\frac{3}{4}$

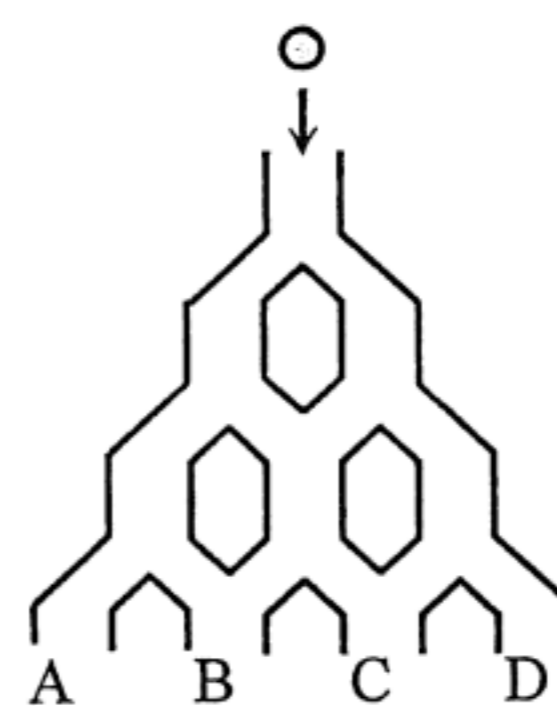

Figure 5

19. In Figure 6,  $PQRS$  is a parallelogram.  $X$  and  $Z$  are points on  $PQ$  and  $SR$  respectively such that  $XZ \parallel PS$ .  $PR$  and  $XZ$  intersect at  $Y$ . It is given that  $PY : YR = 3 : 5$  and the area of  $\triangle PXY$  is  $18 \text{ cm}^2$ . Find the area of  $YZRQ$ .

- A.  $48 \text{ cm}^2$   
B.  $130 \text{ cm}^2$   
C.  $175 \text{ cm}^2$   
D.  $256 \text{ cm}^2$

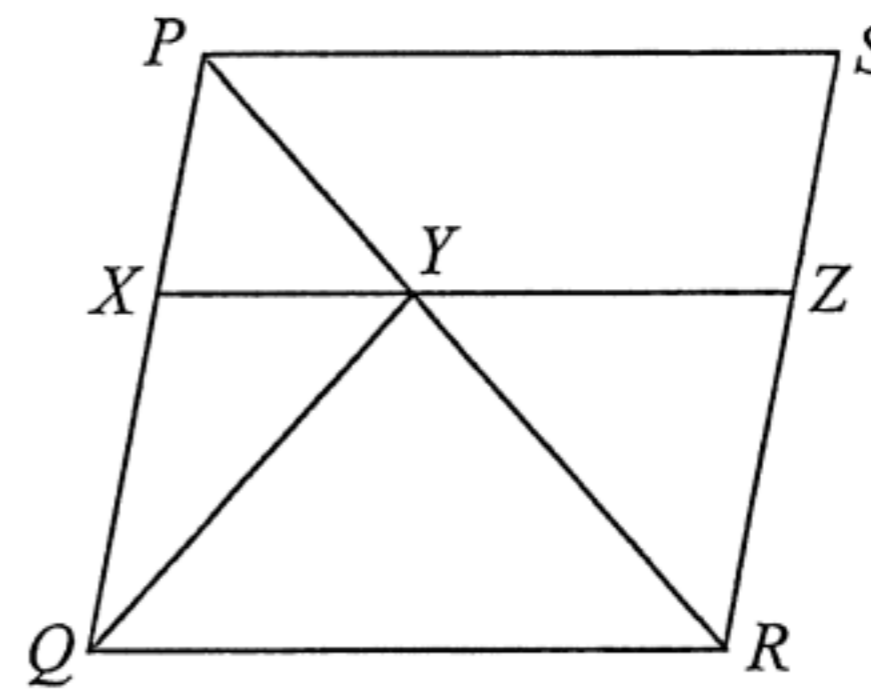

Figure 6

20. Let  $O$  be the origin. The coordinates of  $P$  and  $Q$  are  $(0, p)$  and  $(10, 18)$  respectively, where  $p$  is a positive constant. If the  $x$ -coordinate of the orthocentre of  $\triangle OPQ$  is  $-9$ , then  $p =$

- A.  $-13$ .
- B.  $-\frac{31}{5}$ .
- C.  $\frac{31}{5}$ .
- D.  $13$ .

21. Figure 7 shows a frustum of an inverted right pyramid. Its upper base and lower base are squares. Find the volume of the frustum.

- A.  $1\,952\text{ cm}^3$   
 B.  $2\,560\text{ cm}^3$   
 C.  $3\,200\text{ cm}^3$   
 D.  $5\,856\text{ cm}^3$

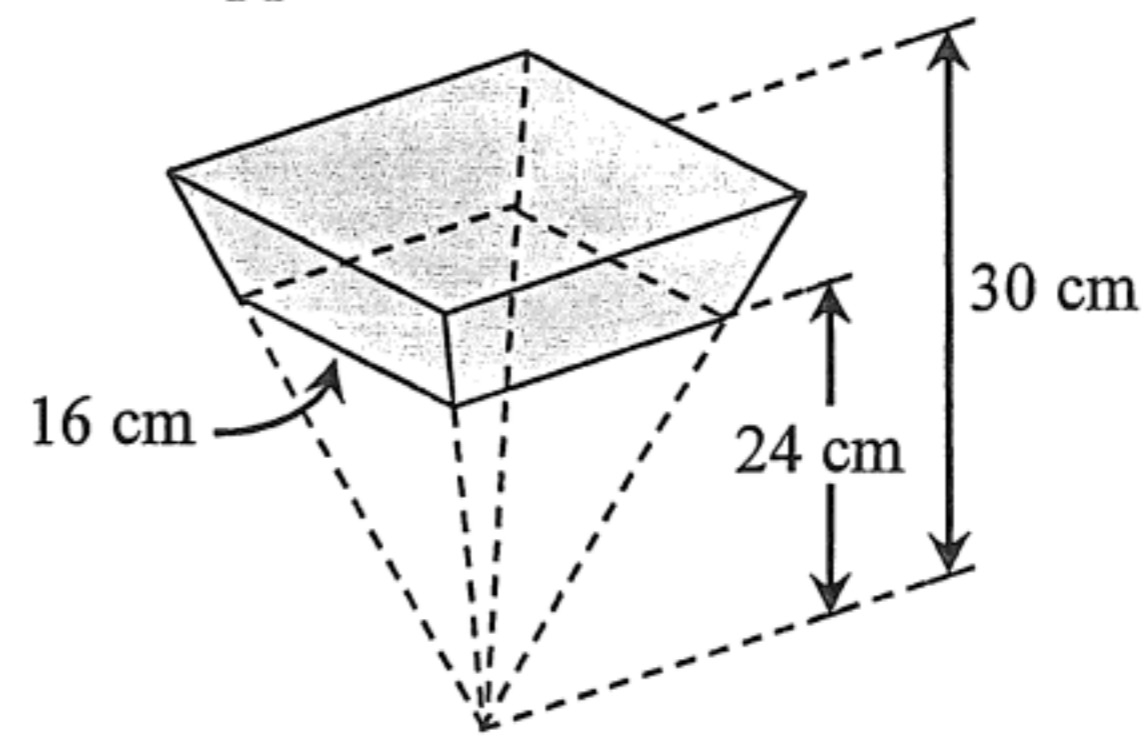

Figure 7

22. In a city, the credit score of a person is the weighted mean of his scores in the amount owed and his payment history. The table below shows these scores of David.

	<i>Amount owed</i>	<i>Payment history</i>
<i>Score</i>	89	95
<i>Weight</i>	$x$	$y$

The credit score of David is 91. Find  $x : y$ .

- A. 1 : 2  
 B. 1 : 3  
 C. 2 : 1  
 D. 2 : 3

23. Mrs Yung deposits a sum of money in a bank. The interest is compounded half-yearly. If the interest rate increases from 4% p.a. to 6% p.a., the interest received after 1 year will increase by \$24 000. Find the sum of the money deposited, correct to the nearest dollar.

- A. \$394 089
- B. \$594 059
- C. \$1 170 732
- D. \$1 203 350

24.  $11001100110_2 =$

- A.  $6 \times 2^7 + 6 \times 2^3 + 6$
- B.  $6 \times 2^8 + 6 \times 2^4 + 6$
- C.  $6 \times 2^9 + 6 \times 2^5 + 6$
- D.  $6 \times 2^{10} + 6 \times 2^6 + 6$

25. In Figure 8,  $ADB$  and  $AEC$  are straight lines.  $BE$  and  $DE$  are the perpendicular bisectors of  $\triangle ABC$  and  $\triangle ABE$  respectively. If  $BE = 4$  cm, find the area of  $\triangle ABC$ .

- A.  $4 \text{ cm}^2$
- B.  $8 \text{ cm}^2$
- C.  $16 \text{ cm}^2$
- D.  $32 \text{ cm}^2$

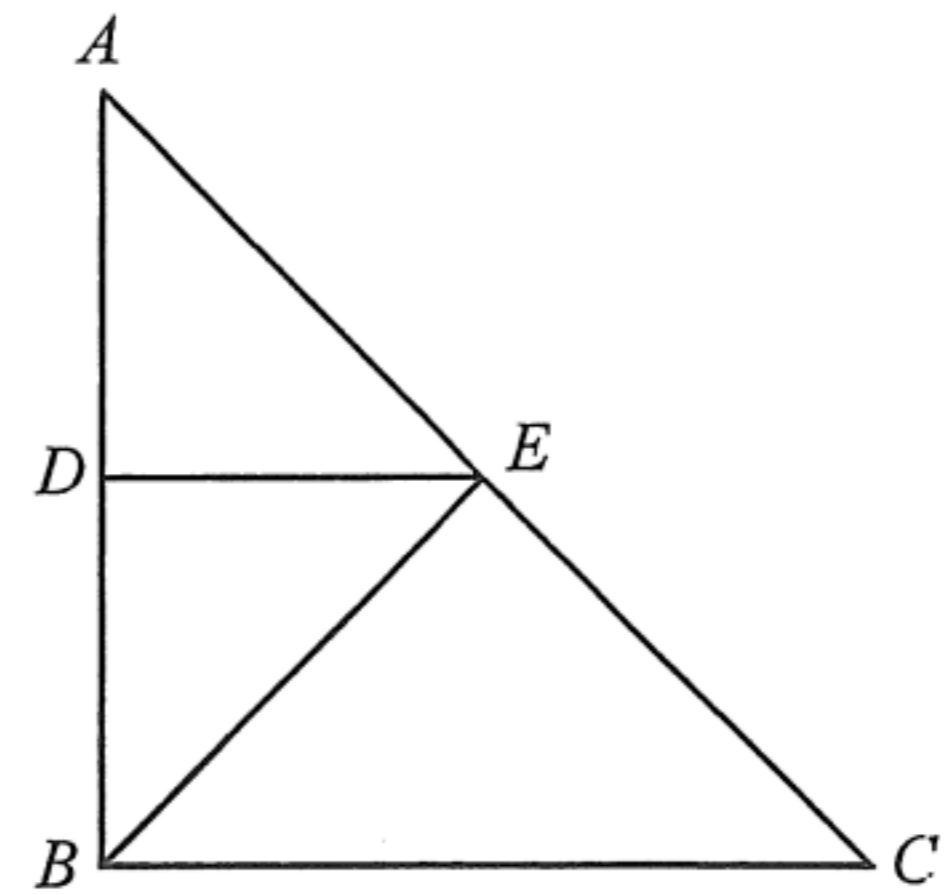

Figure 8

26. In Figure 9,  $ABC$ ,  $CDE$ ,  $AFE$ ,  $GBF$ ,  $GCH$  and  $HDF$  are straight lines. It is given that  $AB = HD$  and  $BCDF$  is a parallelogram. Which of the following are true?

- I.  $\triangle ABF \cong \triangle HDC$
  - II.  $\triangle CBG \cong \triangle FDE$
  - III.  $CEFG$  is a parallelogram.
- A. I and II only
  - B. I and III only
  - C. II and III only
  - D. I, II and III

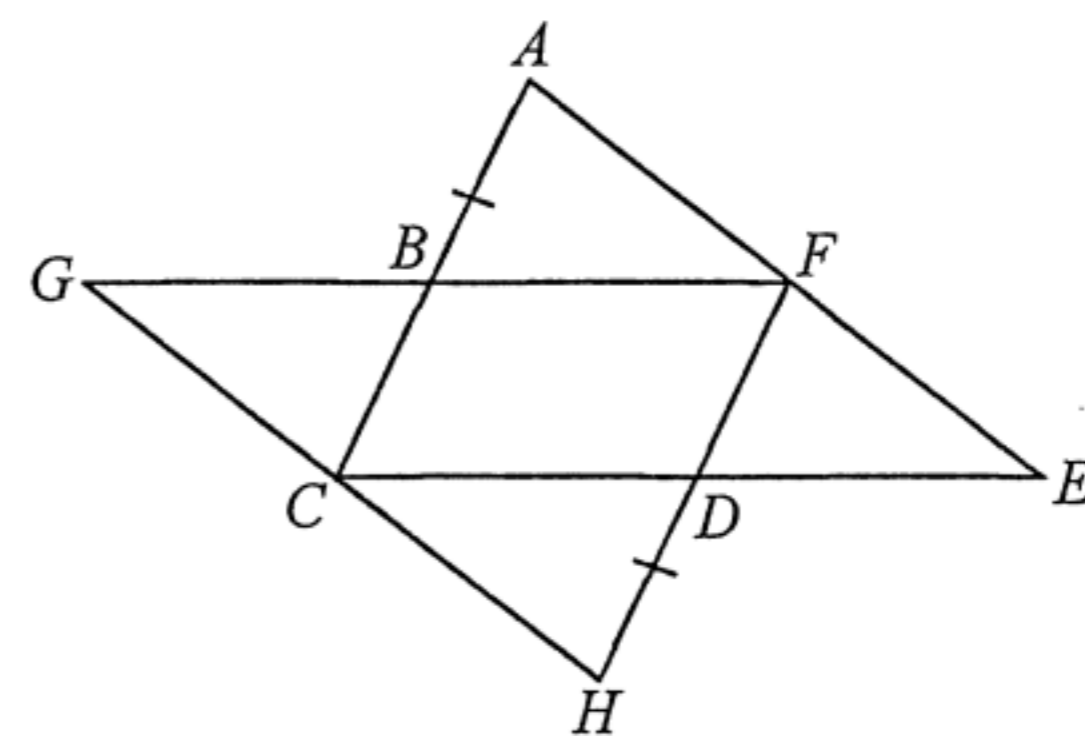

Figure 9



**Bonus Question (3 marks)**

27. Gary plays a game. He pays  $\$x$  and throws a fair dice once. If he obtains a number greater than the host by at least 2, he wins the game. If Gary wins the game and he obtains the number  $a$ , then  $\$10a$  will be awarded. If  $x$  is an integer, find the greatest value of  $x$  such that the game is favourable to Gary.

The following table shows all possible outcomes.

-End of Paper-

