

2018 – 2019
S.3 Mathematics Uniform Test 6
Chapter 6: More about 3-D Figures

Question-Answer Book

Date: 1–2–2019
 Time: 35mins
 This paper must be answered in English

Instructions :

1. Write your name, class and class number in the spaces provided on this cover.
2. Answer ALL questions in this paper. Write your answers in the spaces provided in this Question-Answer Book.
3. Write your answers with black or blue ball-pens, and draw graphs or figures with HB pencils.
4. Unless otherwise specified, all working must be clearly shown.
5. Unless otherwise specified, numerical answers should be either exact or correct to 3 significant figures.
6. The diagrams in this paper are not necessarily drawn to scale.

Section A:
Multiple Choice Questions

1- 7	14	
Total	14	

Section B:
Conventional Questions

8	1	
9	3	
10	3	
11	5	
12	5	
13	3	
14	1	
Total	21	

Bonus	3	
--------------	----------	--

Paper Total	35	
--------------------	-----------	--

Section A: Multiple Choice Questions (14 marks)

Fill in the best answer for question 1-7 in the boxes below.

1	2	3	4	5	6	7

1. In the figures, which thick line is an axis of rotational symmetry of cube $PQRSTU VW$?

A.

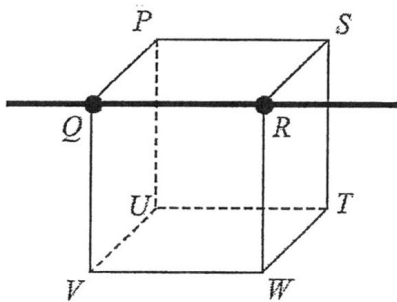

B.

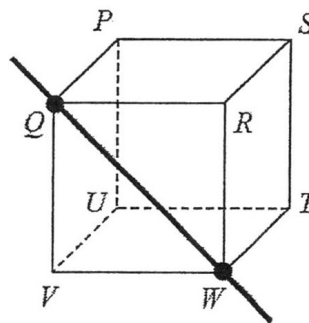

C.

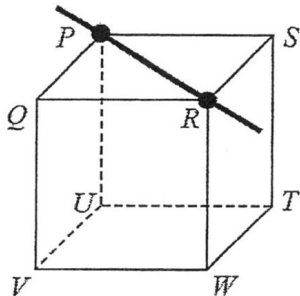

D.

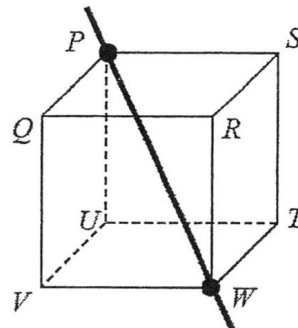

2. The following figure shows a pentagonal prism, whose base is a regular pentagon. When ℓ is the axis of rotation, find the order of its rotational symmetry.

- A. 1
- B. 2
- C. 5
- D. 6

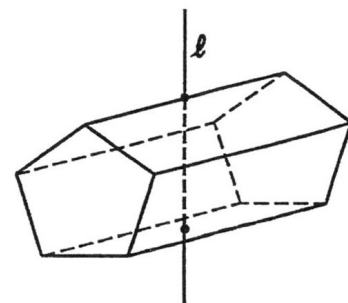

3. Which of the following prisms has two planes of reflection and one axis of rotation only?

A.

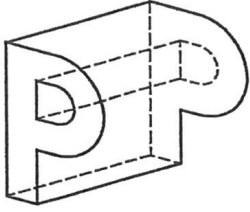

B.

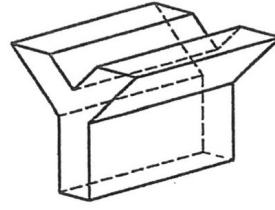

C.

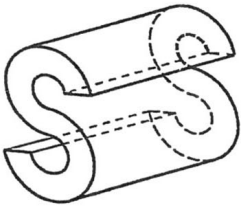

D.

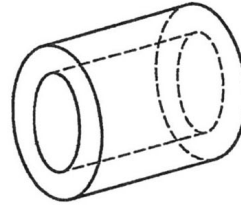

4. According to the front, top and side views of a solid, choose the corresponding 3-D object.

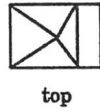
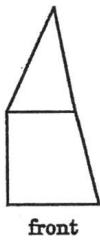

A.

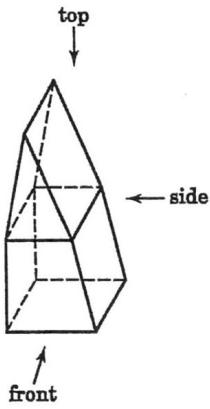

B.

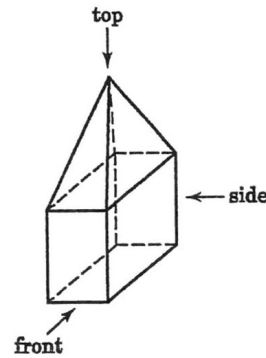

C.

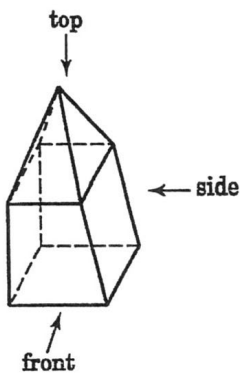

D.

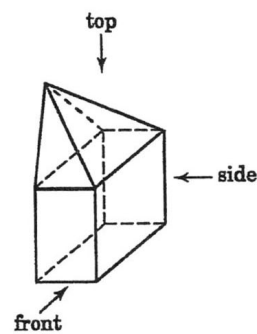

5. Which of the following nets can be folded into a cube?

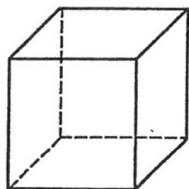

A.

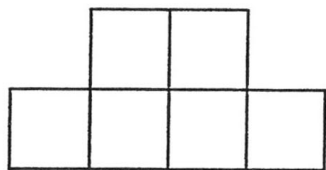

B.

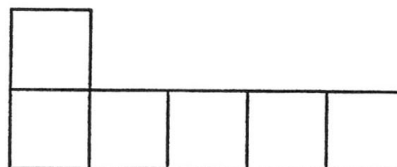

C.

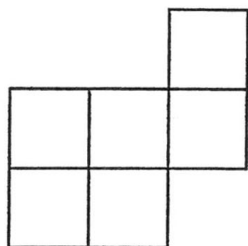

D.

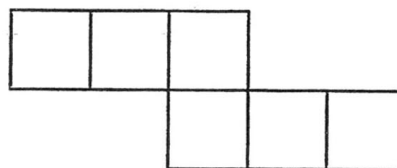

6. Which of the following 3-D figures can be made by the net below?

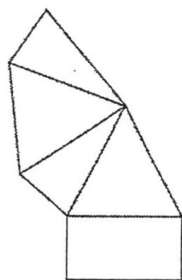

A.

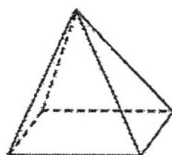

B.

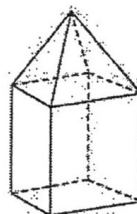

C.



D.

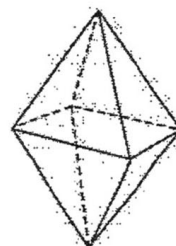

7. The figure shows a right prism, whose base is a right-angled triangle. The angle between $\triangle ABE$ and the plane $ABCD$ is

- A. $\angle ABC$.
- B. $\angle EAB$.
- C. $\angle EAC$.
- D. $\angle EAD$.

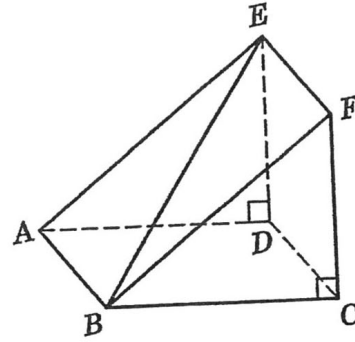

Section B: Convention Questions (21 marks)

8. Figure I shows a cube $ABCDEFGH$. In Figure II, $BGED$ is a plane of reflectional symmetry of the cube.

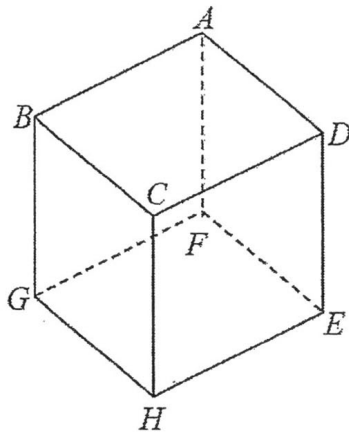

Figure I

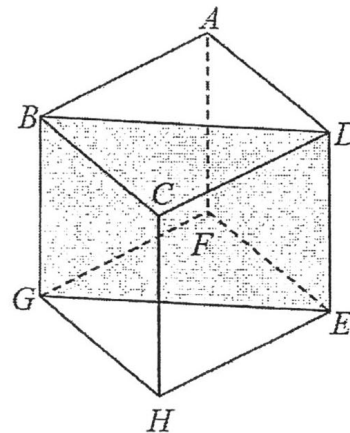

Figure II

(1 mark)

Apart from the plane $BGED$, name **one of the another** planes of reflectional symmetry **containing vertex B**.

Answer: _____

9. According to the following orthographic views, sketch the corresponding object.

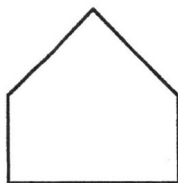

front

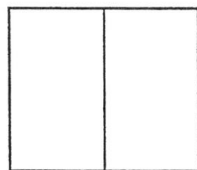

top

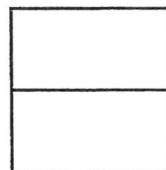

side

(3 marks)

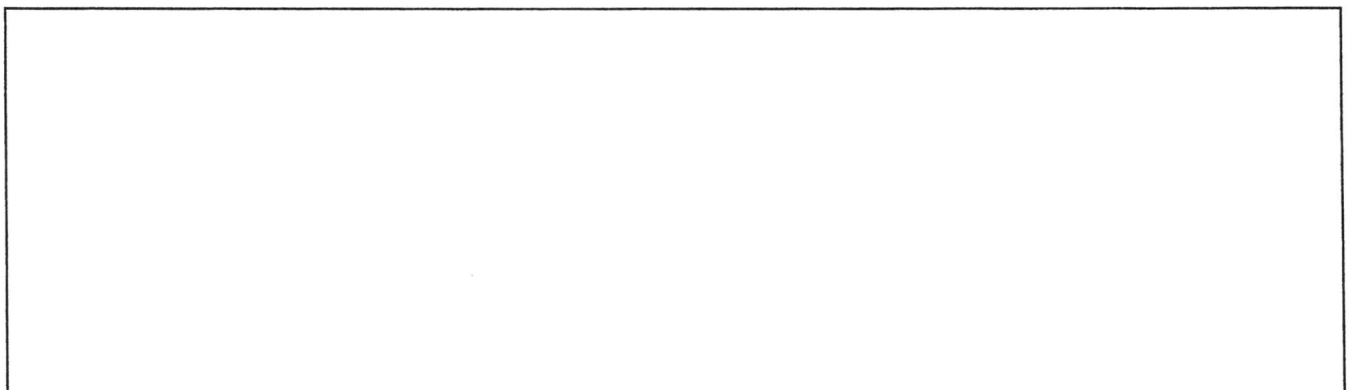

12. In the figure, $ABGFEDCH$ is a cube. M and N are the mid-points of DC and EH respectively.

(5 marks)

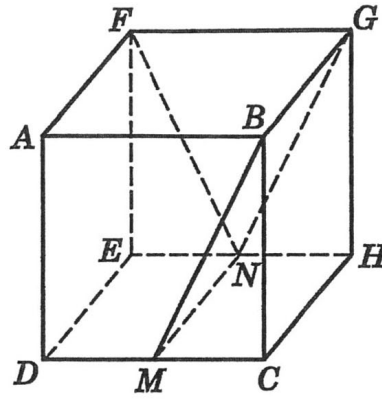

- (a) Name the angle between BM and plane $DCHE$. (a) _____
- (b) Name the angle between FN and plane $ADEF$, (b) _____
- (c) Name the angle between $ABCD$ and plane $BCHG$. (c) _____
- (d) Name the angle between planes $ADHG$ and plane $ADEF$. (d) _____
- (e) Name the angle between planes $BGNM$ and $CHNM$. (e) _____

13. In the figure, $ABCDFE$ is a triangular prism whose base EFD is a right-angled triangle.

(5 marks)

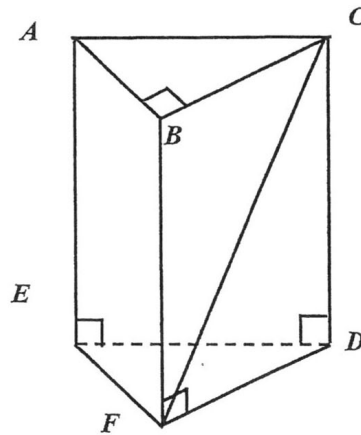

- (a) Name the angle between CF and plane DEF , (a) _____
- (b) Name the angle between planes $ABFE$ and $BCDF$. (b) _____
- (c) Name the angle between the planes ACB and $BFDC$. (c) _____

