

Second Term Test
2024 – 2025
QUESTION-ANSWER BOOK

Subject: **Secondary 2 Mathematics**

Paper: **I**

Time Allowed: **40 minutes**

Total Marks: **80**

INSTRUCTIONS

- (1) Write your name, class and examination number in the spaces provided.
- (2) This paper consists of three sections, A(1), A(2) and B.
- (3) Attempt ALL questions in sections A(1), A(2) and B.
Write your answers in the spaces provided in this Question-Answer Book. Do not write in the margins.
- (4) Unless otherwise specified, all working must be clearly shown.
- (5) The diagrams in this paper are not necessarily drawn to scale.
- (6) Unless otherwise specified, numerical answers should be exact or correct to 3 significant figures.

No. of pages: 11

Page	Marks
2	
3	
4	
5	
6	
7	
8	
9	
10	
11	
Total	

Section A1 (30 marks)

1. The figure shows a circle centre at O with radius 4 cm.

(a) Find the circumference of the circle. (1 mark)

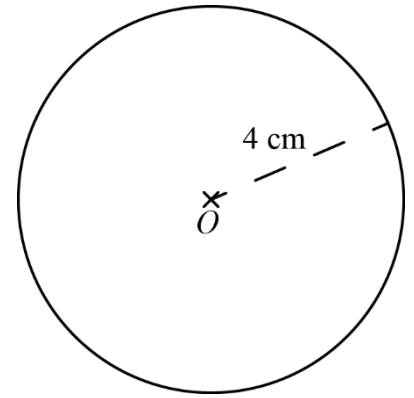

(b) Find the area of the circle. (2 marks)

2. The figure shows a sector OAB centre at O with radius 5 cm and the angle at centre is 240° .

(a) Find the arc length \widehat{AB} of the sector. (2 marks)

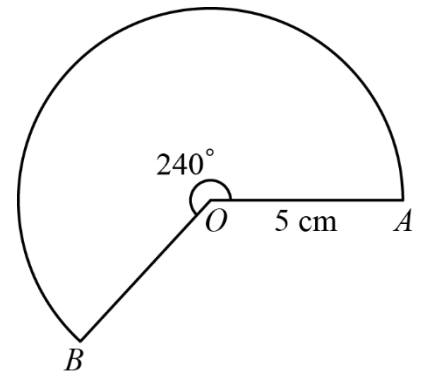

(b) Find the area of the sector. (2 marks)

3. The figure shows a right circular cylinder with base diameter 12 cm and height 15 cm.

(a) Write down the base radius of the cylinder. (1 mark)

(b) Find the volume of the cylinder. (2 marks)

(c) Find the **curved surface area** of the cylinder. (2 marks)

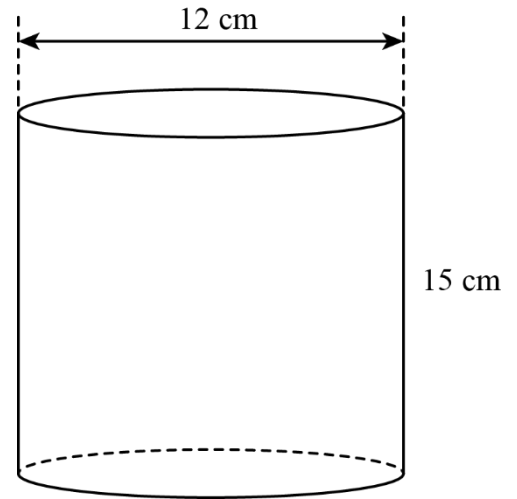

4. In an eating competition, Roy takes 15 minutes to eat 20 bowls of noodles. Find his eating rate in

(a) bowl/min (1 mark) (b) min/bowl (1 mark)

5. Simplify the following ratios.

(a) 24 : 64 (1 mark) (b) $1 : \frac{21}{25}$ (1 mark)

6. If $a : b = 3 : 4$ and $b : c = 6 : 7$, find $a : b : c$. (2 marks)

7. Determine whether the ordered pair $(-1, 9)$ is a solution of the equation $y = 8 - x$. (2 marks)

8. If $(a, -2)$ is a solution of the equation $y + 7 = 5x$, find the value of a . (2 marks)

9. (a) Complete the following tables according to the given equations. (4 marks)

(i) $y + x - 2 = 0$

x	-3	3	5
y			

(ii) $y - 2x + 1 = 0$

x			
y	-5	-1	5

(b) Draw the graphs of $y + x - 2 = 0$ and $y - 2x + 1 = 0$ on the rectangular coordinate plane provided for $x = -5$ to $x = 5$. (3 marks)

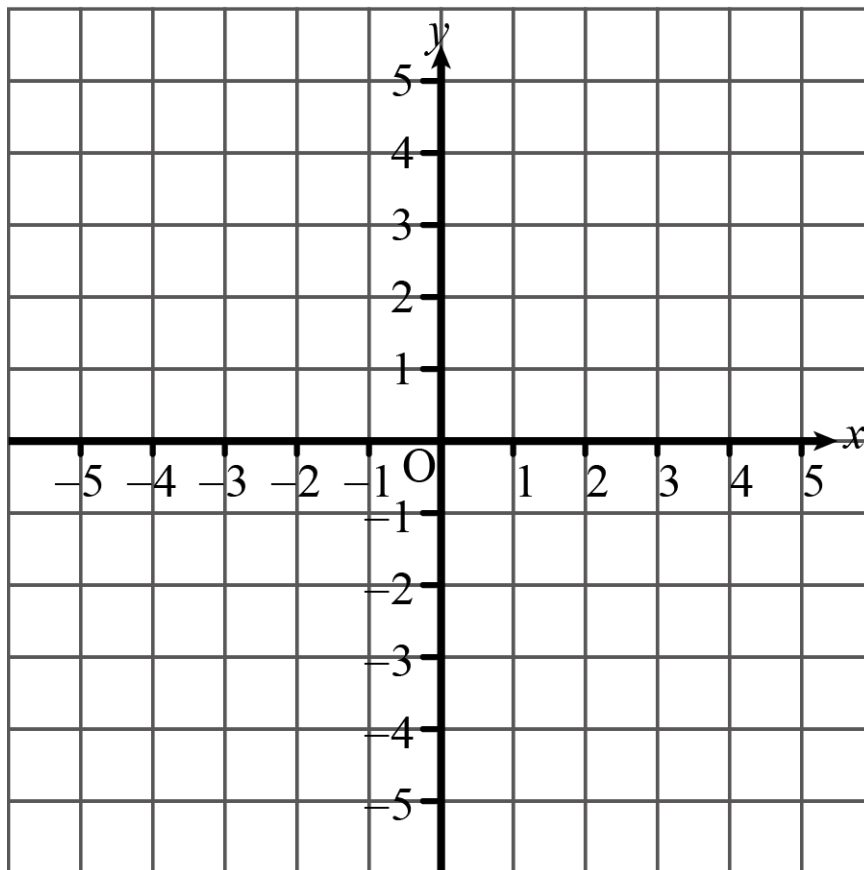

(c) Hence, solve the simultaneous equations $\begin{cases} y + x - 2 = 0 \\ y - 2x + 1 = 0 \end{cases}$ graphically. (1 mark)

Section A2 (30 marks)

10. In the figure, $ABDC$ is a rectangle with $BD = 4$ cm. A semi-circle AEB intersects CD at E . Find the area of shaded region. (4 marks)

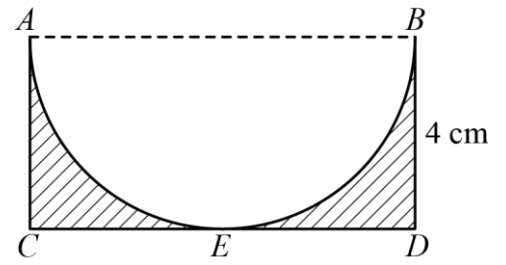

11. The figure shows a sector OAB with radius 12 cm and $\widehat{AB} = 4\pi$ cm. Find the value of θ . (4 marks)

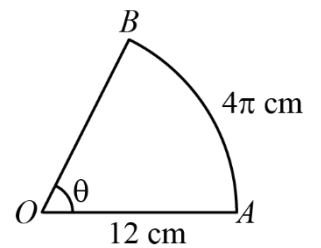

12. The figure shows a solid metallic right circular cylinder with height 30 cm. It is given that the curved surface area of the cylinder is $270\pi \text{ cm}^2$.

(a) Find the base radius of the cylinder.

(2 marks)

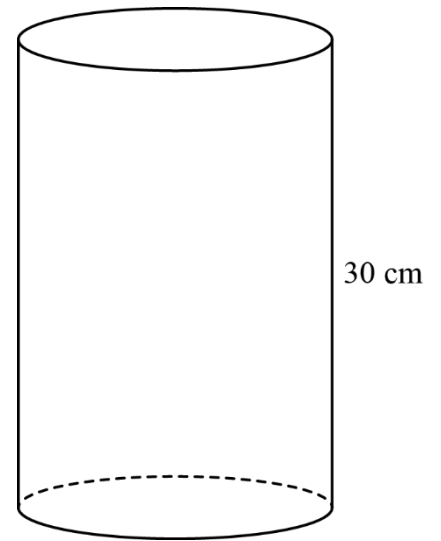

(b) Suppose the metal costs $\$0.5/\text{cm}^3$. Ricky claims that he can make the cylinder at no more than $\$1000$. Do you agree? Explain your answer.

(2 marks)

13. An aeroplane takes 12 hours to travel 11880 km. Find the speed of the aeroplane in m/s. (2 marks)

14. There are 60 students in the Mathematics Society. The ratio of number of male students to number of female students in the Mathematics Society are 3 : 2.
- (a) Find the number of male students in the Mathematics Society. (2 marks)
- (b) If 1 male student left and 4 female students join the Mathematics Society, find the new ratio of number of male students to number of female students in the Mathematics Society. (2 marks)
15. Solve the simultaneous equations $\begin{cases} x = 2y + 5 \\ 3x + y = 22 \end{cases}$ by the **method of substitution**. (4 marks)

16. Solve the following simultaneous equations by the **method of elimination**.

(a)
$$\begin{cases} 3x + 5y = 4 \\ 3x - 2y = -3 \end{cases}$$

(4 marks)

(b)
$$\begin{cases} 7x - 2y = 15 \\ 4x + 2y = 29 \end{cases}$$

(4 marks)

Section B (20 marks)

17. The figure shows a right circular cylindrical metal cup of uniform thickness 1 cm, including its base, containing some water. The height and outer diameter of the cup are 25 cm and 10 cm respectively. After totally immersing 5 metallic cubes with side 2 cm into the water of the cup, the water level increases h cm.

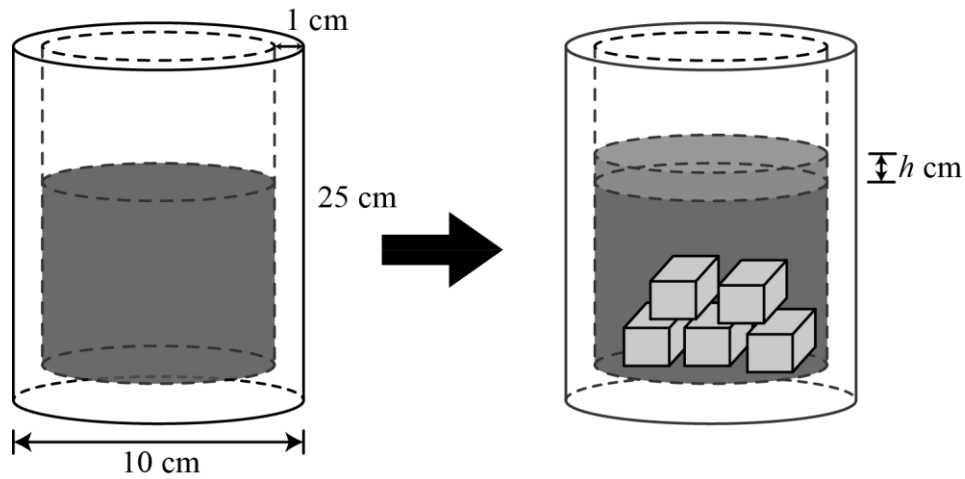

(a) Find the total volume of the 5 metallic cubes. (2 marks)

(b) Find the value of h . (4 marks)

(c) Find the increase in the area of the wet surface of the tank. (2 marks)

18. In a bank, the exchange rate between the Hong Kong Dollar (HKD) and the Thai Baht (THB) is 4.36 THB / HKD. Mr. Chan wants to buy a hotel in Thailand at THB 7 800 000. How many HKD should he exchange? (2 marks)
(Give your answer correct to 3 significant figures.)
19. Simplify the ratio $2500 \text{ cm}^2 : 4 \text{ m}^2$. (2 marks)
20. The total price of 4 pens and 5 pencils is \$47 whereas the total price of 2 pens and 3 pencils is \$25. Let x and y be the prices of each pen and pencil respectively.
- (a) Set up a pair of simultaneous equations in x and y . (2 marks)
- (b) Hence, find the value of x and y . (4 marks)
- (c) Mr. Lee has \$50. Does he have enough money to buy 3 pens and 9 pencils? Explain your answer. (2 marks)